

POLIESTER REFORZADO FIBRA DE VIDRIO

COLORES

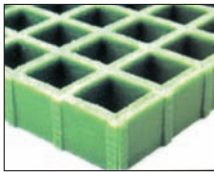

Malla 38x38-30 antideslizante

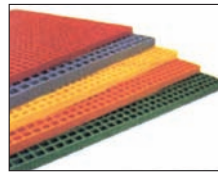

Gama de colores

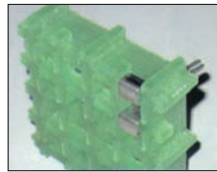

Acabado traslúcido



Chapas lagrimadas, antideslizante

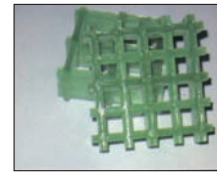

Mallas traslúcidas 38x38-20x20

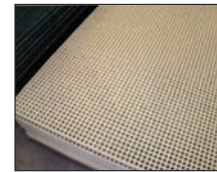

Malla 20x20-30 antideslizante

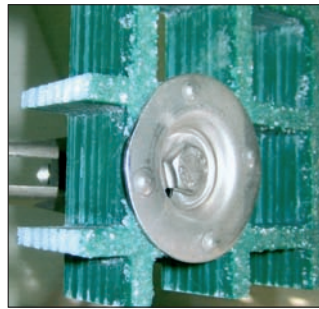

Grapa de sujeción. Inoxidable

RESINAS ESTANDAR

GP - RESINA ORTOFTÁLICA (GENERAL PURPOSE) Verde (RAL 6010)	Resina de Poliester auto-extinguible (ASTM-E84/ M1 F1) resistente U.V. aprobada DNV. -50° C +52° C
ISO - RESINA ISOFTÁLICA Verde (RAL 6010)	Resina de Poliester auto-extinguible (ASTM-E84/ M1 F1) resistente U.V. aprobada DNV y USDA (Departamento de agricultura de los EE.UU. color gris) -50° C +66° C
ISO - RESINA ISOFTÁLICA Gris (RAL 7040)	
VE - RESINA VINYLESTER Naranja (RAL 2002)	Resina de Poliester auto-extinguible (ASTM-E84/ M1 F1) resistente U.V. aprobada DNV. -50° C +82° C
ELS - RESINA ACRÍLICA Gris (RAL 7044)	Resina Acrílica ignífuga (ASTM-E84/ M1 F1, baja emisión de humo) resistente U.V. -50° C +85° C
XFR - RESINA DE VINYLESTER MODIFICADA Gris (RAL 1013)	Resina de Vinylester auto-extinguible resistente a los rayos U.V. aprobada por la DNV - 70° C +95° C
PHE - RESINA FENÓLICA Marrón (RAL 8001)	Resina ignífuga. Alta resistencia a ácidos y disolventes. Temperatura de utilización hasta 180° C.

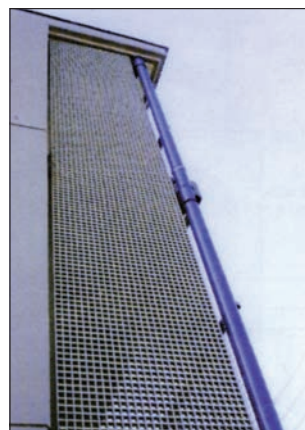
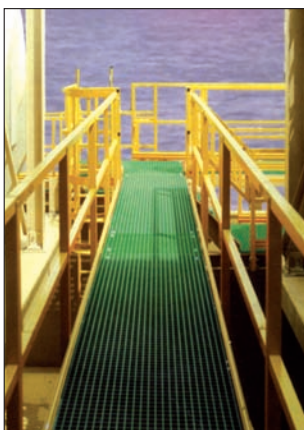

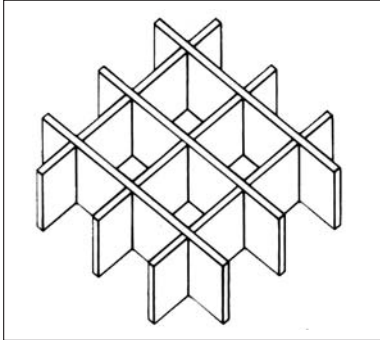
TRAMEX MANUAL

Pletinas iguales doble
encaste

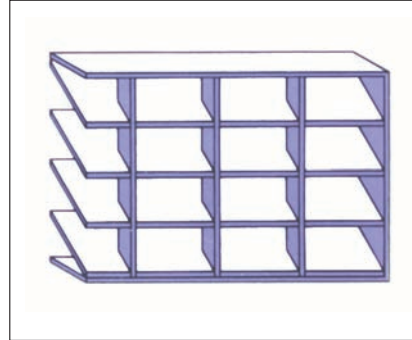
TRAMEX MANUAL

Tipo persiana

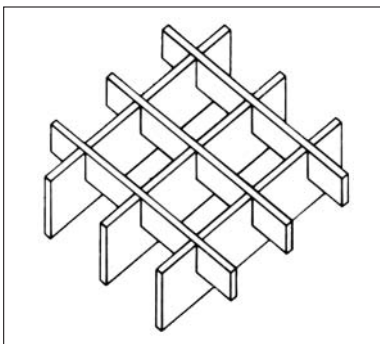

Pletinas desiguales
encaste en pletina
portante

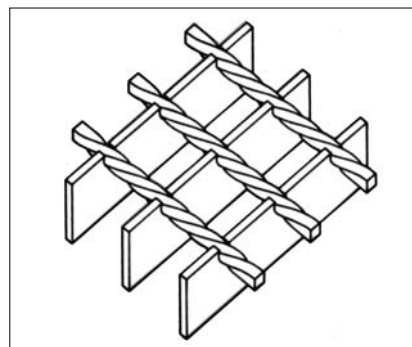
EMPARRILLADO ELECTROFUNDIDO

Pletina con varilla
entregirada

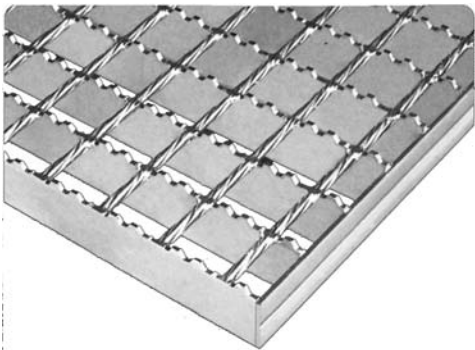
TRAMEX DENTADO**TRAMEX CON PERFIL DE PROTECCIÓN 8x8
(Malla de seguridad)**

SE FABRICA EN CUALQUIER MEDIDA

TRAMEX INOXIDABLE

AISI-304 - AISI 316
Acabados pulido y
decapado

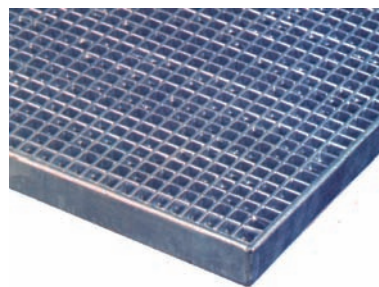
TRAMEX LUZ PEQUEÑA

SE FABRICA EN CUALQUIER MEDIDA

ESCALERAS, PELDAÑOS

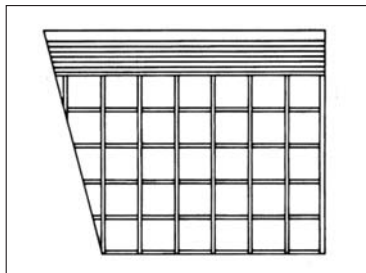

Todos nuestros peldaños van provistos de un **Frontal de Seguridad**.

El Frontal de Seguridad también puede ser colocado en los rellanos.

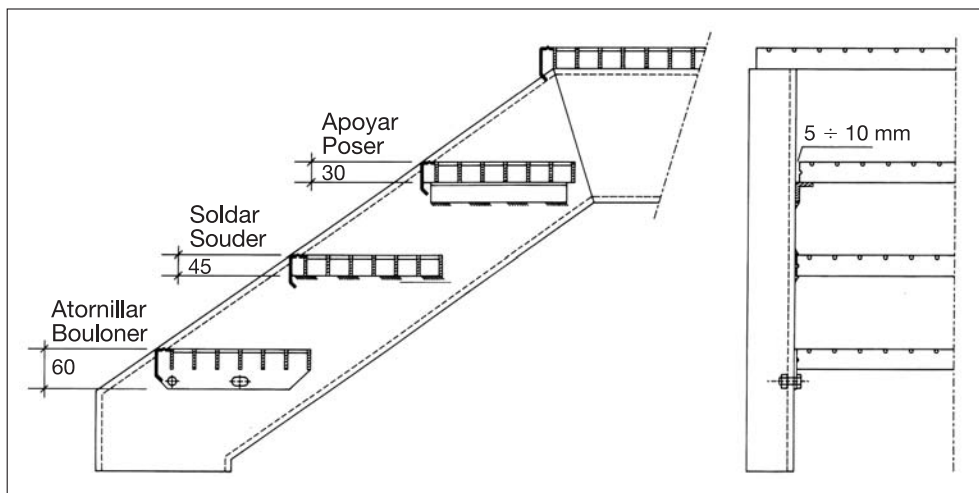
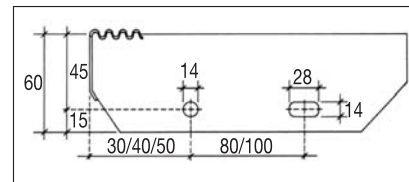

HUELLAS

200 x medida	30/80
240 y 270	40/100
300	50/100

TRAMEX GALVANIZADO STOCK PERMANENTE

30x30 / 30x2 O 5	30x30 / 30x3 O5	30x30 / 30x2-10x2	DENTADO 30x30 / 30x2 O5	P.P. 8x8 30x30 / 30x2 O5	DOBLE DENTADO 30x30 / 30x3-10x2
200 x 1000	1000 x 1000	1000 x 1000	1000 x 1000		
250 x 1000					
300 x 1000					
400 x 1000					
500 x 1000		2000 x 1000	2000x1000	2000 x 1000	2000 x 1000
600 x 1000	600 x 1000				
700 x 1000			DENTADO	P.P. 8x8	
800 x 1000		30x30 / 30x2-30x2	30x30 / 30x3 O5	30x30 / 30x3 O5	
900 x 1000					
1000 x 1000	1000 x 1000	1000 x 1000	1000 x 1000	1000 x 1000	
1200 x 1000	1200 x 1000				
1500 x 1000	1250 x 1000				
2000 x 1000	1500 x 1000				
1000 x 2000	2000 x 1000	2000 x 1000	2000 x 1000	2000 x 1000	
850 x 2000	3000 x 1000				
3000 x 1000					

PELDAÑOS

30x30 / 30x2 O 5	30x30 / 30x3 O5	30x30 / 40x3 O5	P. ATORNILLAR 30x30 / 30x2 O5	P.P. 8x8 30x30 / 30x2 O5	P.P. 8x8 30x30 / 30x3 O5
500 x 200					
600 x 240			600 x 240	600 x 240	900 x 270
700 x 240				700 x 240	
700 x 270				700 x 270	
800 x 240			800 x 240	800 x 240	
800 x 270				800 x 270	
1000 x 300	900 x 270				
	1000 x 300				
	1200 x 300				
		1500 x 300			

La primera medida corresponde a la pletina portante, la segunda a la varilla.
Se corta a medida y con forma. Existen otras medidas de TrameX (según las cargas).

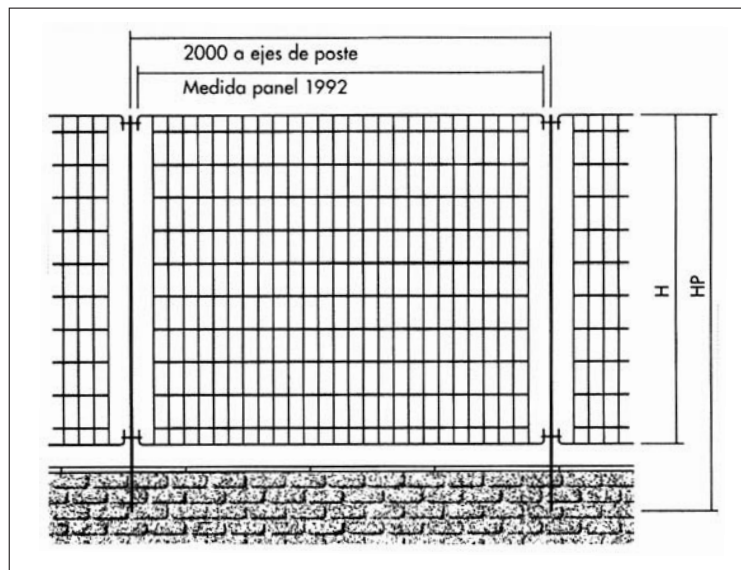
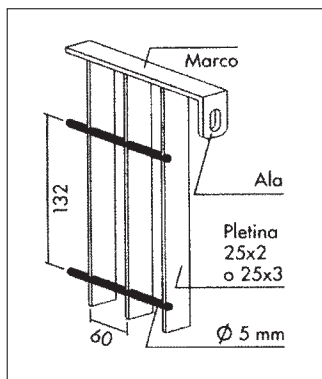
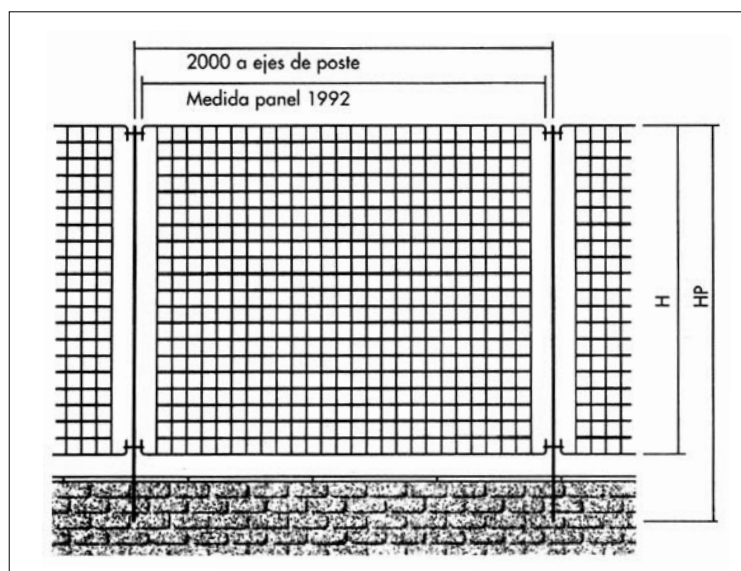
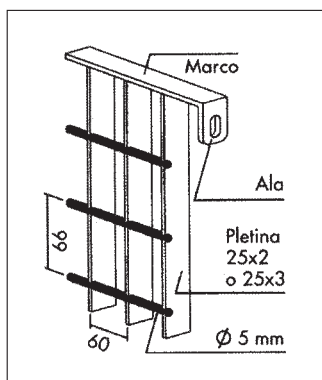
CERCAS / VALLAS STANDARD**60x120****60x60**

Suministramos el material en:

- Acero negro galvanizado según norma UNE-EN ISO 1461:1999
- Lacado según tabla de colores RAL
- Acero inoxidable

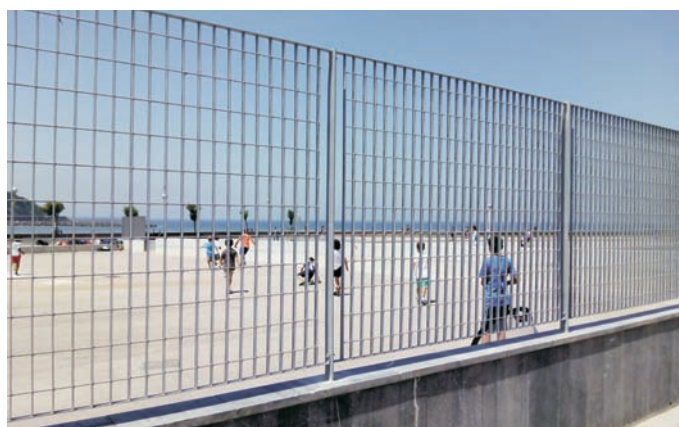

Cercado - Explanada Sagües - Donostia

TABLA DE CARGAS DE REJILLAS ELECTROFUNDIDO



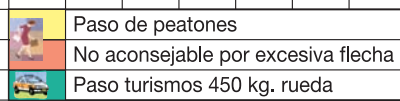





		DISTANCIA EN MM. ENTRE APOYOS																						
		200	300	400	500	600	700	800	900	1000	1100	1200	1300	1400	1500	1600	1700	1800	1900	2000	2100	2200	2300	2400
20x2	U				1900	1320	970	742																
	fu				1,56	2,25	3,06	4,00																
	C				155	125	104	89																
	fc				1,5	2,16	2,86	3,66																
20x3	U				2851	1980	1454	1113	880	712														
	fu				1,56	2,25	4,00	5,06	6,25	7,5														
	C				234	186	155	133	117	104														
	fc				1,56	2,16	2,86	3,66	4,56	5,56														
25x2	U				2970	2062	1514	1160	916	742	613													
	fu				1,25	1,80	2,45	3,2	4,05	5,0	6,05													
	C				243	194	162	138	121	107	97													
	fc				1,25	1,73	2,29	2,93	3,64	4,44	5,32													
25x3	U				4454	3093	2272	1740	1374	1113	920	773	658	568										
	fu				1,25	1,80	2,45	3,20	4,06	5,00	6,05	7,20	8,45	9,80										
	C				365	292	243	208	182	162	146	132	121	112										
	fc				1,25	1,73	2,29	2,93	3,64	4,44	5,32	6,28	7,32	8,44										
30x2	U				4275	2969	2181	1670	1320	1069	883	742	632	545										
	fu				1,04	1,5	2,04	2,67	3,38	4,17	5,04	6,00	7,04	8,17										
	C				350	280	234	200	175	155	140	127	117	107										
	fc				1,04	1,44	1,91	2,44	3,04	3,70	4,44	5,24	6,10	7,04										
30x3	U				6414	4454	3272	2505	1980	1603	1324	1113	948	817	712	626	554							
	fu				1,04	1,50	2,04	2,67	3,38	4,17	5,04	6,00	7,04	8,17	9,38	10,67	12,04							
	C				526	421	350	300	236	234	209	191	175	162	150	140	131							
	fc				1,04	1,44	1,91	2,44	3,04	3,70	4,44	5,24	6,10	7,04	8,04	9,10	10,24							
30x5	U				11520	8000	5878	4500	3556	2880	2380	2000	1704	1469	1280	1125	997	889	798					
	fu				1,3	1,9	2,6	3,4	4,3	5,3	6,4	7,6	8,9	10,4	11,9	13,5	15,3	17,1	19,1					
	C				956	764	636	545	478	425	382	348	319	294	273	255	239	225	213					
	fc				1,3	1,8	2,4	3,1	3,9	4,7	5,6	6,6	7,7	8,9	10,2	11,6	13,0	14,5	16,1					
35x3	U				8730	6063	4454	3410	2693	2183	1803	1516	1292	1113	969	852	755	673	604					
	fu				0,89	1,29	1,75	2,29	2,89	3,57	4,32	5,14	6,04	7,00	8,04	9,14	10,32	11,57	12,89					
	C				715	573	477	409	358	317	286	259	238	220	204	191	178	168	158					
	fc				0,89	1,23	1,63	2,09	2,60	3,17	3,80	4,49	5,23	6,03	6,89	7,80	8,77	9,80	10,89					
40x2	U				7602	5274	3879	2969	2345	1900	1570	1320	1124	969	844	742	657	586						
	fu				0,78	1,12	1,53	2,00	2,53	3,13	3,78	4,50	5,28	6,13	7,03	8,00	9,03	10,12						
	C				624	493	415	356	312	277	248	226	207	191	178	165	155	146						
	fc				0,78	1,08	1,43	1,83	2,28	2,78	3,33	3,93	4,58	5,28	6,03	7,68	8,58	9,43						
40x3	U				11402	7919	5818	4454	3519	2851	2355	1980	1686	1454	1266	1113	986	880	789	712	646			
	fu				0,78	1,13	1,53	2,00	2,53	3,13	3,78	4,50	5,23	6,13	7,03	8,00	9,03	10,13	11,28	12,50	13,78			
	C				934	748	624	534	467	415	374	339	312	287	266	249	234	220	207	197	186			
	fc				0,78	1,08	1,43	1,83	2,28	2,78	3,33	3,93	4,58	5,28	6,03	6,83	7,68	8,58	9,53	10,53	11,58			
40x4	U				15204	10558	7756	5939	4692	3801	3142	2640	2249	1939	1688	1484	1314	1172	1053	950	861	785		
	fu				0,78	1,13	1,53	2,00	2,53	3,13	3,78	4,50	5,28	6,13	7,03	8,00	9,03	10,13	11,28	12,50	13,78	15,13		
	C				1247	997	831	712	624	554	498	453	415	383	356	332	312	293	277	262	248	237		
	fc				0,78	1,08	1,43	1,83	2,28	2,78	3,33	3,93	4,58	5,28	6,03	6,83	7,68	8,58	9,53	10,53	11,58	12,68		
40x5	U				20475	14219	10446	7998	6319	5119	4230	3555	3029	2612	2275	2000	1771	1580	1418	1280	1161	1058	968	889
	fu				1,00	1,4	1,9	2,5	3,2	4,0	4,8	5,7	6,7	7,8	8,9	10,2	11,5	12,9	14,3	15,9	17,5	19,2	21,0	22,9
	C				1670	1336	1113	954	835	742	682	607	557	514	477	445	418	393	371	351	334	318	303	291
	fc				1,00	1,4	1,8	2,3	2,9	3,5	4,2	5,0	5,8	6,7	7,7	8,7	9,7	10,9	12,1	13,4	14,7	16,1	17,6	19,1
50x4	U				25590	17771	13056	9996	7898	6397	5287	4443	3785	3264	2843	2499	2214	1975	1772	1599	1451	1322	1209	1111
	fu				0,8	1,1	1,6	2,0	2,6	3,2	3,8	4,6	5,4	6,2	7,1	8,1	9,2	10,3	11,5	12,7	14,0	15,4	16,8	18,3
	C				2055	1644	1370	1174	1027	914	840	745	685	632	587	548	514	483	457	433	411	391	374	357
	fc				0,8	1,1	1,5	1,9	2,3	2,8	3,4	4,0	4,6	5,4	6,1	6,9	7,8	8,7	9,7	10,7	11,8	12,9	14,0	15,3
60x5	U				32000	23510	18000	14222	11520	9521	8000	6817	5878	5120	4500	3986	3558	3191	2880	2612	2380	2178	2000	
	fu				1,0	1,3	1,7	2,1	2,6	3,2	3,8	4,5	5,2	6,0	6,8	7,6	8,6	9,6	10,6	11,7	12,8	14,0	15,2	
	C				2911	2426	2079	1819	1617	1488	1323	1212	1120	1039	970	910	856	809	766	728	694	661	633	
	fc				0,9	1,2	1,5	1,9	2,4	2,8	3,3	3,9	4,5	5,1	5,8	6,5	7,3	8,1	8,9	9,8	10,7	11,7	12,7	



U: Carga uniformemente repartida
 fu: Flecha U en mm.
 C: Carga concentrada sobre una superficie de 200x200
 fc: Flecha C en mm.

Paso de peatones
 No aconsejable por excesiva flecha
 Paso turismos 450 kg. rueda

TABLA DETALLE CARGAS PESADAS

VÁLIDO PARA TODAS LAS MALLAS 34,3 DE PLETINA PORTANTE									
CARGAS PESADAS									
	Carga rueda (kg)	450	1000	2000	3500	5000	1000	2000	3500
	Huella mm.	160x160	200x200	200x200	250x250	250x250	140x140	160x160	200x200
Longitud máx. entre apoyos (mm.)	25x3	325	250	175	175	150	175	125	125
	30x2	325	225	175	175	150	175	125	125
	30x3	450	300	200	200	175	200	150	150
	30x5	700	425	250	250	200	300	200	200
	35x3	575	375	225	225	175	275	175	175
	40x2	500	325	200	200	175	225	175	150
	40x3	750	450	275	250	200	325	225	200
	40x4	950	575	350	300	225	400	275	225
	40x5	1175	700	400	325	275	500	325	250
	45x5	1450	850	475	375	300	625	400	300
	50x4	1450	850	475	375	300	625	375	300
	60x5	1900	1425	775	575	450	1100	625	475

GAVIONES Y CORAZAS

GAVIONES Y CORAZAS

Gaviones y corazas para defensas fluviales, canalización y revestimiento de ríos y canales, muros de contención contra avenidas, derrumbamiento y corrimiento de tierras en montes y barrancos, autopistas y autovías, corrección de cauces, espigones, consolidación de firmes en vías férreas, carreteras, caminos, etc., refuerzo de presas, diques, malecones, defensa de plantaciones forestales y similares, drenajes, protección y reparación de taludes y otras aplicaciones.

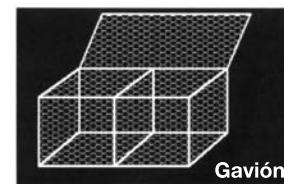

ENREJADO TRIPLE TORSIÓN Malla 5 x 7 - 13 (2,00 mm.)

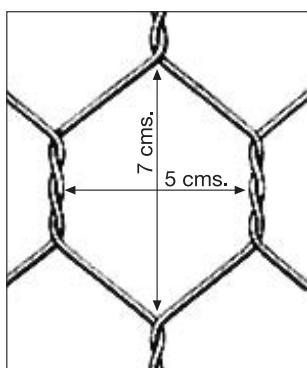

ENREJADO TRIPLE TORSIÓN Malla 8 x 10 - 16 (2,70 mm.)

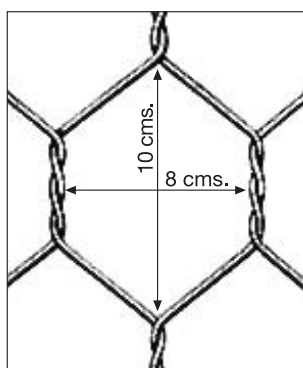

ENREJADO CINCO TORSIONES Malla 6,5 x 9 - 13 (2,00 mm.)

